

Garbage Segregation and Monitoring Using Low-Cost IoT System for Smart Waste Management

Muhammad Azlan Bakar¹, Yusnaidi Md Yusof^{2*}, Suriani Mohd Sam³, Azizul Azizan⁴, Noor Azurati Ahmad⁵, Hafiza Abas⁶, Noraimi Shafie⁷

^{1,2,3,4,5,6,7}Razak Faculty of Technology and Informatics,
Universiti Teknologi Malaysia, 54100 Kuala Lumpur
¹azlan89@graduate.utm.my, ²yusnaidi.kl@utm.my,
³suriani.kl@utm.my, ⁴azizulazizan@utm.my, ⁵azurati@utm.my,
⁶hafiza.kl@utm.my, ⁷noraimi.kl@utm.my

Article history

Received:
14 May 2023

Received in revised form:
18 June 2023

Accepted:
23 June 2023

Published online:
27 June 2023

*Corresponding author
yusnaidi.kl@utm.my

Abstract

Waste management is one of the serious issues in maintaining the longevity of life. Managing waste in garbage bins not only requires a systematic garbage segregation policy but also a prevention and control mechanism for human behaviour. With the aid of the low-cost-budget Internet of Things (IoT) approach, managing garbage bins for municipal and town councils become practical, effective, and easy to be enforced. This study proposed a proof-of-concept prototype of a low-cost IoT approach using Raspberry Pi and cheap sensor modules to segregate waste into garbage bins with local alarming and remote notification systems. The systems are capable of detecting metal and non-metal waste so that segregation can be applied, and measuring waste levels in the garbage bin to prevent waste overflow. On top of that, the systems are also able to warn with loudness sound of a mistype waste scanned at the bin lid and send prompt notifications to the remote observer for further actions. The study results from a number of performance testing demonstrated the developed systems can accurately measure waste levels either to be empty, half-filled, or 80% filled when the ultrasonic ranging module sensor is placed 105° inside the bin. This is the best positioning we recommended when working with a bin of size 15 cm in height and 10 cm in width. Finally, we observed that the finest detection results were achieved when the movement of objects are scanned less than 2 cm, but not more than 4 cm away.

Keywords: Smart Garbage, Internet of Things (IoT), Smart Waste Management, Garbage Segregation

1. Introduction

The increase in the world population has a proportional impact on the amount of garbage that is produced every day at a rapid rate as now becoming a global problem. The world's municipal solid waste (MSW) is 2.01 billion metric tonnes annually of which, 33 percent is not satisfactorily managed in an environmentally safe manner. The waste generated per person per day averages 0.74 kilograms and ranges widely from 0.11 to 4.54 kilograms, whereas ASEAN's per capita MSW generation is 1.14 kg/capita/day [1]. The lack of solid waste planning and financial investment in waste management has resulted in inadequate and poorly operated facilities contributing to environmental pollution, which is hazardous to public health.

* Corresponding author. yusnaidi.kl@utm.my

Based on the data from the U.S. Environmental Protection Agency that has been issued in 2018 [5], from the total 292 million tons of waste produced in a year, 50% of it is going to be landfilled and only 23.6% was recycled. There is a serious need for a waste management solution by leveraging the benefit of modern green technology for a smarter solution to this problem. Thus, the main concern is how to segregate the waste item and make sure the potentially recyclable waste item will not be sent to waste disposal land and disrupt environmental surroundings.

Poor garbage management not only can affect the population but also pose serious threats like infectious diseases, obstruction of drains, land and water pollution, and loss of biodiversity. Garbage that often overflows from public garbage can congregate on roads and rivers leading to pollution and an increase in carbon footprint [2]. On one hand, the use of biodegradable waste can be decomposed by nature. However, non-degradable waste that cannot be decomposed will cause it to accumulate and pollute the environment [3][4].

If waste is not separated properly, it will get mixed up in the waste landfill, requiring manual segregation for proper waste management. Manual segregation of waste items is an unhygienic dirty job that usually comes from economically backward areas [3]. Persons handling such waste face social discrimination and marginalisation due to the nature of their job, apart from being exposed to unintended diseases and hazardous substances that may threaten life. The citizens must put an act in the early process of waste segregation by categorizing public or household garbage as the top priority. A sense of responsibility and taking ownership of the waste they produced can help in solving the issue from the root.

Current conventional waste management systems only focus on collection schedules based on the population density of the specific area. The garbage segregation policy that has been enforced cannot change the citizen behaviour on how they segregate their waste into correct categories i.e., metal, paper, and plastic. This problem has caused a major problem for a city to manage its waste management properly and lose control of the activities of the citizen to maintain the waste segregation policy that has been enforced. Hence, there is a need for a waste management system to introduce modern technology that involves IoT as a part to monitor and manage the collection schedule time at the same time can control and maintain the citizen behaviour for waste segregation.

Internet of Things (IoT) has the potential to substantially improve waste management systems by increasing operational efficiency, optimising resource utilisation, and facilitating real-time monitoring and data-driven decision-making. According to [5], by leveraging IoT technologies, waste management can become more economically viable through the optimal utilization of resources. It can lead to substantial time and monetary savings by optimizing trip length and vehicle utilization [6]. Moreover, IoT implementation in waste management can also contribute to improved fuel efficiency and reduced manpower requirements [7]. According to [8], the Internet of Things (IoT) has significantly improved the quality and effectiveness of waste management practices. Furthermore, IoT implementation has played a crucial role in addressing public health concerns and supporting local authorities in their waste management efforts [9].

According to [10] and [11], real-time monitoring capability in IoT can facilitate the monitoring of waste status by municipal authorities and cleaner workers through IoT cloud-based systems. In summary, the implementation of the Internet of Things (IoT) in waste management systems offers numerous benefits to the conventional waste management system. Given that cost is an important consideration for stakeholders prior to the adoption of IoT in waste management systems, it is of the utmost significance to design a cost-effective IoT device. The subsequent literature review seeks to investigate the existing research on low-cost efficient smart waste management systems, with a particular emphasis on addressing the limitations and benefits identified in earlier studies.

[12] proposed an IoT-based trash-checking system that utilized Arduino or Raspberry Pi board and ThingSpeak. The framework consisted of an ultrasonic sensor, a Wi-Fi module, and a heap battery. The ultrasonic sensor determined the depth of the trash in the container, while the load cell estimated the weight of the waste bin. However, during the experiment, the author observed that the database was unable to update the information when the trash height exceeded 90 cm, resulting in the inability to submit the trash data to the database. As a result, the application continued to display the previous details without updating. [13] presented a spot automatic trash segregation device that can separate metals, dry garbage, and wet waste. The device utilized a parallel resonance impedance system for separating metallic waste, and capacitive sensors for segregating wet and dry waste. Notably, the study did not include efficiency testing and sensor accuracy assessment to ascertain the practicality of the designed model in real-world scenarios.

[14] put forth the concept of an efficient garbage system consisting of stationary and autonomous garbage bins. The web server and an Android application are utilized to update the garbage level and status of each bin, generating alert notifications for remote monitoring. To enhance the alert system, a camera is integrated with the bin to detect discarded trash and emit a sound. Even so, the authors proposed a credit reward system based on a Wi-Fi card to incentivize and acknowledge environmentally friendly behaviour.

However, further study is needed to investigate behavioural changes resulting from the credit reward system. This is due to the additional effort required from users to receive credit and the potential for users to dispose of improper waste without the system detecting whether it meets the criteria for credit reward. [15] presented an IoT-based smart garbage monitoring system that involved sending real-time sensor data using NodeMCU to the ThingSpeak cloud. The researchers utilized the free web service 'ThingSpeak' as a host to gather data from various sensors and facilitate live status visualization, monitoring, and management of garbage flow through GPS-enabled trucks employing efficient algorithms. Although the system exhibited a commendable data interface with location detection, a notable limitation was the absence of garbage type separation in the design, which is a crucial element in smart garbage systems.

[10] developed an IoT-based system for waste management, enabling monitoring of garbage depth inside the dustbin and providing notifications of its full condition via a mobile phone and the Blynk apps. The system utilized an ultrasonic sensor to measure the level of garbage inside the dustbin. The garbage status was displayed

on an LCD, and an ESP8266 WiFi module was employed to transmit the information to the smartphone. However, it is important to note that the WiFi module may not function properly in areas with limited network coverage or availability. Therefore, future improvements should focus on the development of more robust communication hardware.

In conclusion, the reviewed studies demonstrate the potential of IoT in improving waste management systems. However, limitations were identified such as data update issues, lack of efficiency testing, absence of garbage type separation, and limitations in areas with poor network coverage. Future research should focus on addressing these limitations to optimize IoT-based waste management solutions.

1.1. Waste Management

IoT-based waste management is one of the numerous domains in garbage monitoring systems. The emergence of IoT is intensifying present-day waste management with encouraging technology and social forecast. A typical waste management system uses interconnected smart devices to create a network for waste level analysis, monitoring of trash cans; and identifying situations where the waste management authority's involvement is required.

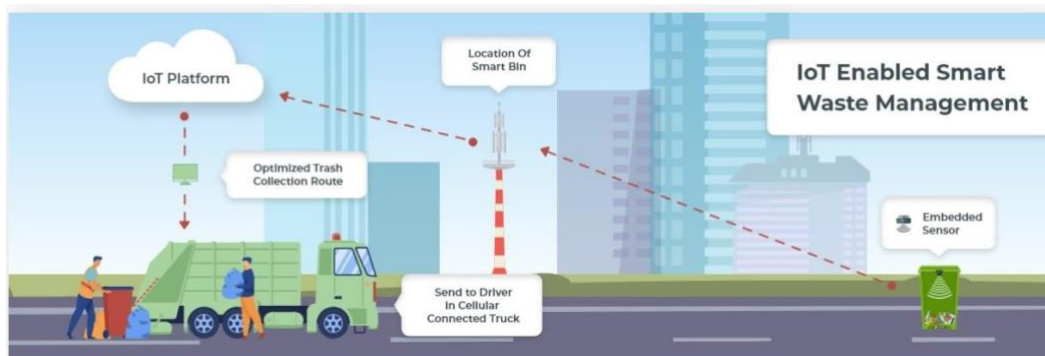

Figure 1. IoT-Enabled Waste Management System

Instead of a conventional garbage bin, IoT-aided remote garbage monitoring systems are masked with sensors and identifiers which can be exclusively identified over the internet. It appears to be an information retriever, from the real world to the electronic world [16]. Figure 1 example of smart waste management in a smart cities application.

In Smart Cities, the efficiency of the smart waste management system is fundamental [17]. To address the issue, this project proposed an Internet of Things (IoT) based waste segregation system. The aim is to automate the process of waste segregation for items of different materials like metal and non-metal. The proposed system potentially can improve the recycling process from the source of waste which is the public trash can.

2. Design and Implementation

An architecture for IoT-technology-based applications is essential when considering attributes such as reliability, scalability, interoperability, and quality of service (QoS) [8]. The IoT framework's first layers consist of devices, sensors, and actuators. The sensor can help to sense the presence of materials that do not belong to the correct trash can. The signal will be sent to the actuator/buzzer to warn the person to segregate the waste properly. At the same time, the sensor will measure the level of garbage in the trash can and use IoT's network layer as a communication medium to send and connect the data to the middleware layer for the computing process. Data collected that is stored in the middleware layer can be used by authorities in the application layer for waste management scheduling and big data analytics.

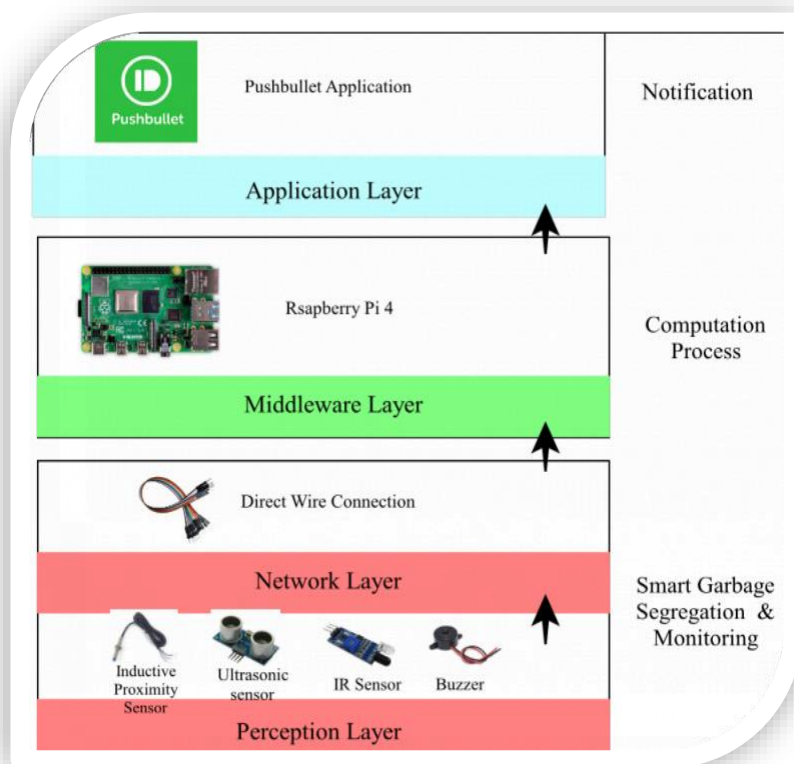

Figure 2. Proposed Architecture Layer

The study proposed three main layers of architecture as demonstrated in Figure 2, that consist of perception & network layer, middleware layer, and application layer. The perception layer is the layer where all the sensors and actuators are located, and they are directly connected to the middleware layer. In the middleware layer, Raspberry Pi is used for the computation of data received from the perception layer. The processed data is then sent to the Pushbullet application in the application layer, where a push notification showed in the registered mobile device for mobile viewing.

2.1. System Setup

The system developed in this study consists of several hardware and software. Table 1 comprises a list of hardware names, models, and detection functions of the hardware that has been used for this study.

Table 1. List of Hardware and Model

Hardware Name	Model Name	Function / Detect
Raspberry Pi	Pi 4 Model B 2GB	Processing
Inductive Proximity Sensor	LJ12A3-4-Z/BX	Metal
Ultrasonic Ranging Module	SR04P	Garbage Level
Infrared Sensor Module	SN-IR-MOD	Motion
Buzzer	SO-PIEZO-22045	Sound
Relay	SRD-05DVC-SL-C	Voltage
Battery	9V EVEREADY	Power RPi

The Raspberry Pi is a single-board computer that runs Linux, and provides a set of GPIO pins, allowing it to control electronic components for physical and IoT-based computing. This study uses Raspberry Pi Model B for computation services and a number of sensors for garbage segregation purposes. For example, the study uses inductive proximity sensors to detect metal targets, ultrasonic ranging sensors to measure the distance to an object and garbage level in the bin, infrared sensors to sense objects' motion in the surrounding, buzzers to alarm devices, timers, and confirmation of user input, and relay to separate the external voltage from the 9V battery and the internal voltage from Raspberry Pi GPIO. The relay also acts as a switch. When the metal is detected by the inductive proximity sensor, it will trigger the relay circuit to connect the GPIO 3.3v pin with the GPIO input pin for further actions. Figure 3 shows a connection between the Raspberry Pi and the breadboard.

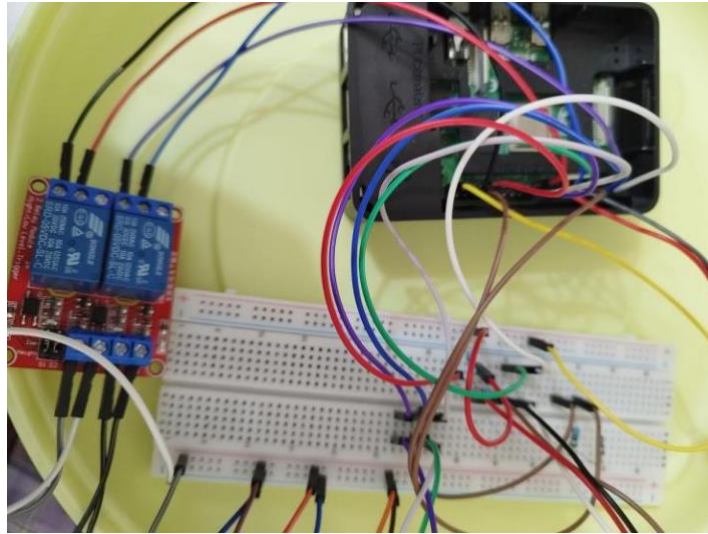

Figure 3. Relay Connection to the Raspberry Pi

The software used in the study is Mu Python editor for code editing and the PushBullet productivity app to send notifications from the coding program straight to mobile devices. In this study, the PushBullet will send a notification to a registered mobile device if the garbage level is more than 80% full.

2.2. Experimental Design

The sensors are interconnected to the Raspberry Pi through the breadboard. The usage of a resistor and relay helps to control the voltage and protect the voltage circulation within Raspberry Pi to be below the maximum voltage allowed. On the other hand, a Python program is constructed to manage input tasks to action output. Figure 4 illustrated the hardware connection design of the study.

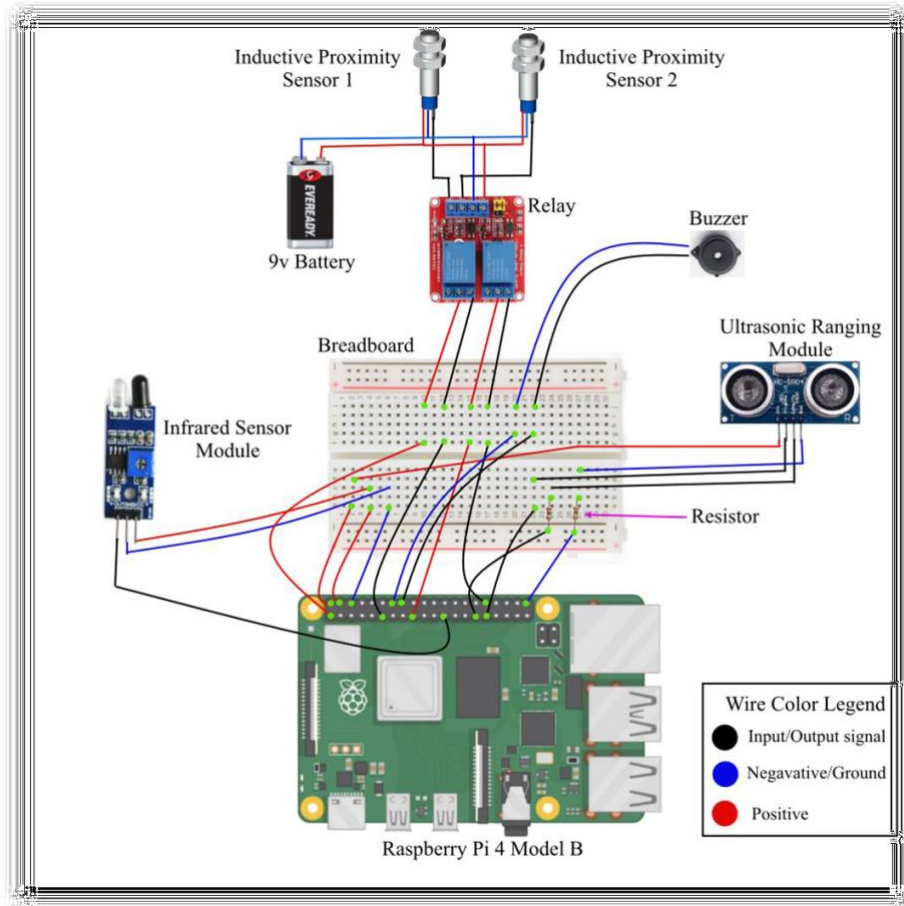

Figure 4. Hardware Connection Diagram

We experimented with garbage segregation with two separated bin types: metal only and plastic & paper only, with their names of Bin 1 and Bin 2 respectively. The handling of garbage segregation is to detect the presence of metal and motion in Bin 1 and 2, and the measurement of garbage level. The inductive proximity sensor is positioned at the front top of both Bins (shown in Figure 5), while the ultrasonic sensor is positioned at the back of Bin 2 (shown in Figure 6).

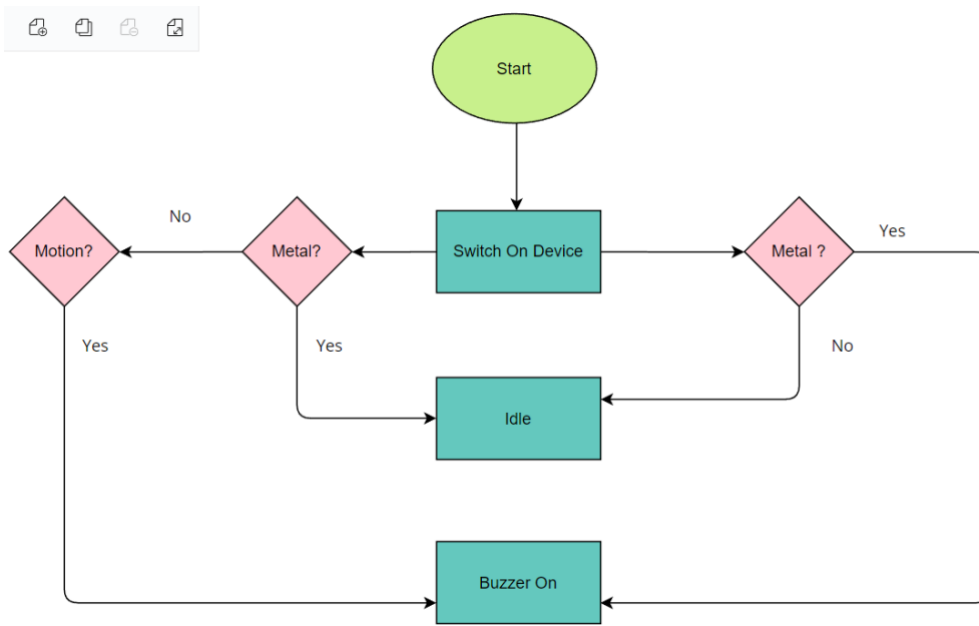

Figure 7. Flow Diagram of Metal and Motion Detection

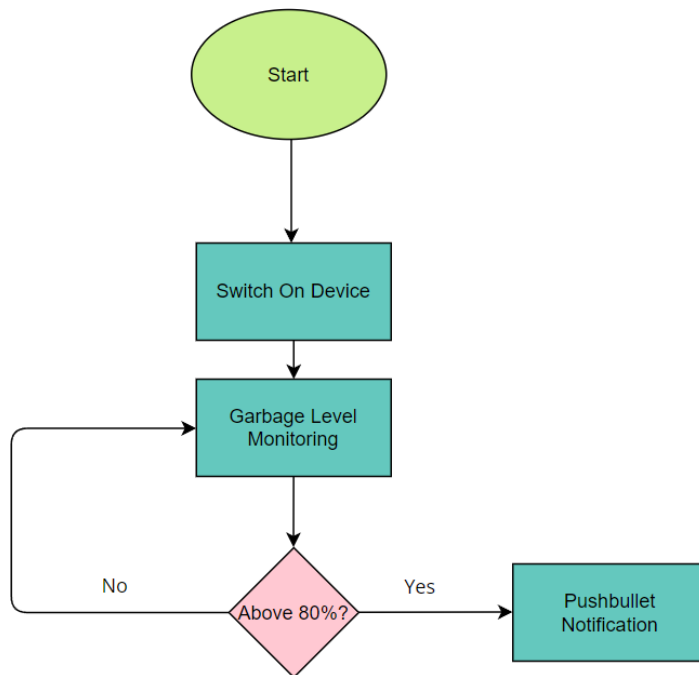

Figure 8. Flow Diagram of Garbage Level Detection

2.3. Testing Procedure

The infrared sensor module is used as a motion sensor to detect an object that is inserted into the garbage bin. The performance of motion detection is primarily determined by doing normal testing of the sensor sensitivity and the distance of detection. An inductive proximity sensor is used as a metal detection sensor to detect material from metal and the performance of metal detection is gained by determining the sensitivity and distance of the detection. A buzzer is used as a device to produce loud sounds with the purpose to warn a person from throwing rubbish into the wrong garbage bin. The test was held to measure the performance of the warning reactivity and the loudness of the warning alerts.

Finally, the ultrasonic ranging module is used as a garbage level monitoring sensor. The sensor module SR04P provides stable and accurate distance measurements from 2 cm to 450 cm. It has a focus of fewer than 15 degrees and an accuracy of about 2 mm. The sensor uses ultrasonic sound to measure distance. Ultrasonic sound produces high pitch sounds of about 40 kHz that humans cannot even hear it. Two main parts of the sensor are the transducer, to create ultrasonic sounds, and the receiver, to listen for its echo.

To measure distance using the ultrasonic sensor, we programmed Python codes that measure the travel time of the ultrasonic sounds. Sound travels at approximately 340 metres per second. This corresponds to about 29.412 microseconds per centimetre. To measure the distance the sound has traveled, the formula for the calculation is as follows:

$$Distance = \frac{Time}{2} \times 34300$$

$$Distance = Time \times 17150$$

$$\% \text{ of Garbage Level} = \frac{Height \text{ of Garbage Bin} - Distance}{Height \text{ of Garbage Bin}} \times 100$$

Assuming the height of the garbage bin is 17 cm, therefore,

$$\% \text{ of Garbage Level} = \frac{17 - Distance}{17} \times 100$$

As shown in Figure 9, the testing consisted of garbage level and the ultrasonic sensor positioning degree. In order to get the optimum positioning of the ultrasonic sensor in the garbage bin, we adjust and tested it with five different positioning degrees against five levels of garbage. The first level is equal to 0% of garbage or empty garbage, while the fifth level is equal to a level of nearly full which we considered to be already filled with more than 80%. This is the threshold level we marked in the experiment.

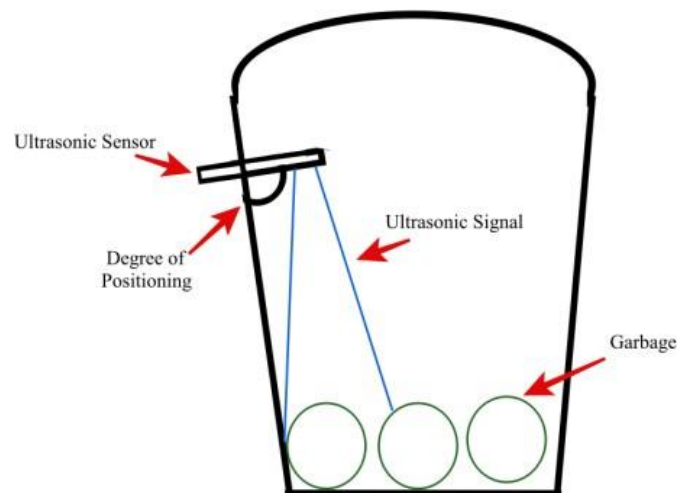

Figure 9. Positioning Degree of the Ultrasonic Sensor

Instead of continuous real-time garbage monitoring, the system was designed to send notifications when the garbage level was more than 80% full. This approach helps to reduce buffer overloading due to queue overflow of sensing packet processing. The fewer packets transmission on the air also ensures lesser signal disruption in the communication channel. We performed notification performance testing by measuring the notification reception time from the time the notification is sent by the system.

3. Results and Analysis

The study has the main objective to design waste segregation alarms to alert a person and to make sure the garbage is segregated properly. The developed systems also aimed to monitor the garbage level and send notifications through a mobile device. Such objectives are evaluated based on five separate but interrelated performance tests we conducted throughout the experimentation of the study. The tests measure the performance of metal detection, motion detection, warning alarm alerting, garbage level monitoring, and garbage level notification.

3.1. Metal Detection

The study's main objective is to segregate the metal and non-metal material in the designed garbage bin. As per physical testing, the results showed that the performance of inductive proximity sensor LJ12A3-4-Z/BX is very sensitive and highly accurate when detecting metal at a distance of fewer than 2cm. Once the metal is detected in Garbage Bin 1, the system will send the warning alert through the buzzer and stop immediately when the metal material

is removed from the sensor. Figure 10 and Figure 11 demonstrated the Terminal snapshot of the metal detection test.

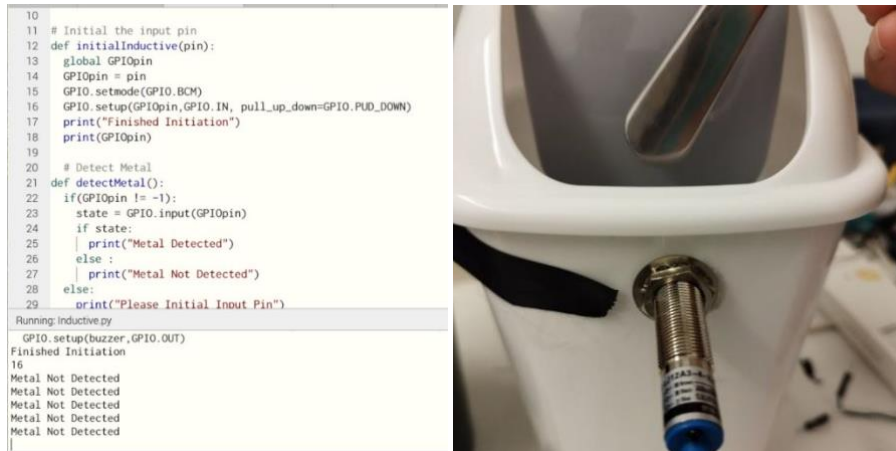

Figure 10. No Metal is Detected When No Metal Material is Inserted in the Garbage Bin 2

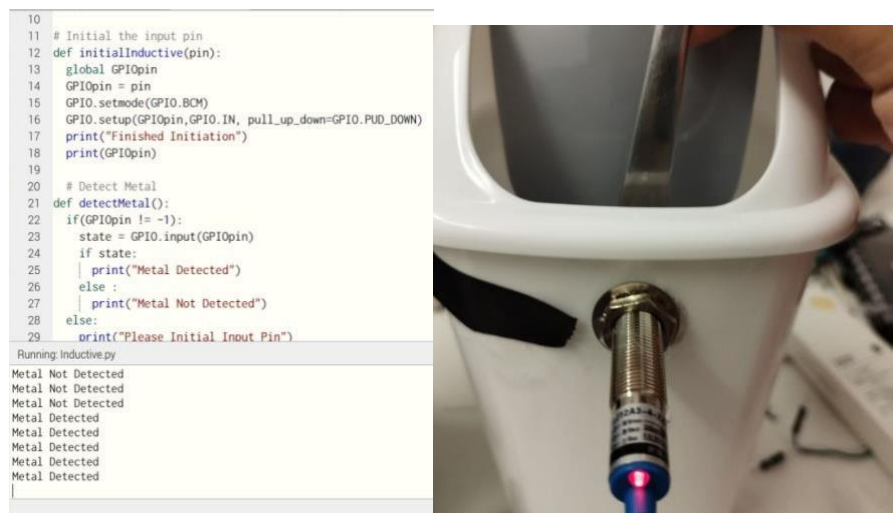

Figure 11. Metal Detected When Metal Material is Inserted in the Garbage Bin 2

3.2. Motion Detection

In this experiment, the infrared sensor module is used with the combination of an inductive proximity sensor to detect the movement of non-metal material and is put into a Garbage Bin 2. If the sensor failed to detect any metal material movement, the system sends a warning alert through a buzzer. After performing a physical test as shown in Figures 12 and 13, the infrared sensor indicated that it is highly sensitive when defining any movement in a range of 3-4 cm. The system can detect the movement and react concurrently.



Figure 12. No Motion is Detected When No Metal-Object is Inserted in the Garbage Bin 2

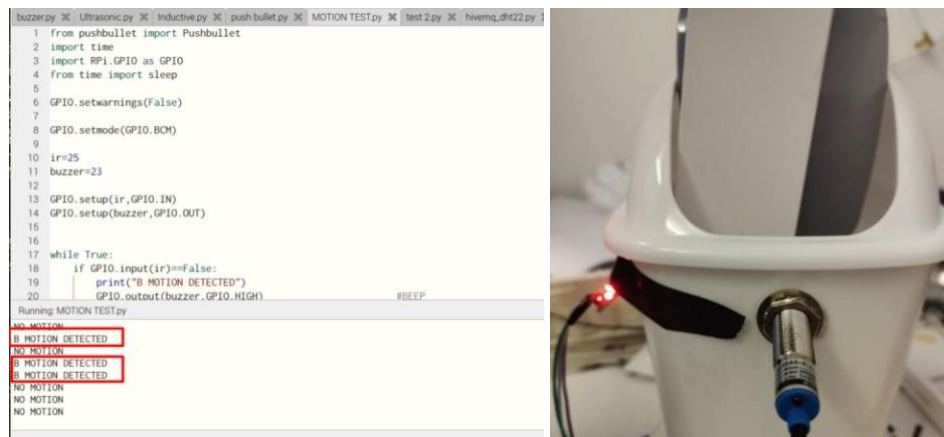

Figure 13. Motion is Detected When Metal-Objects are Inserted in the Garbage Bin 2

3.3. Warning Alarm Alerting

An electric buzzer is a simple device that is used to send warning and alert sounds to the person that unethically used a garbage bin. Based on the test result, the buzzer managed to send a warning with an adequate level of volume to warn a user of the action and immediately prevent the throwing of garbage into the wrong bin.

3.4. Garbage Level Monitoring

The ultrasonic ranging module is used to measure the level of garbage in the garbage bin. The test is performed to check the accuracy of distance measurement for the ultrasonic sensor in the garbage bin based on the degree of angle of its position. The results of the test are presented in Figure 14.

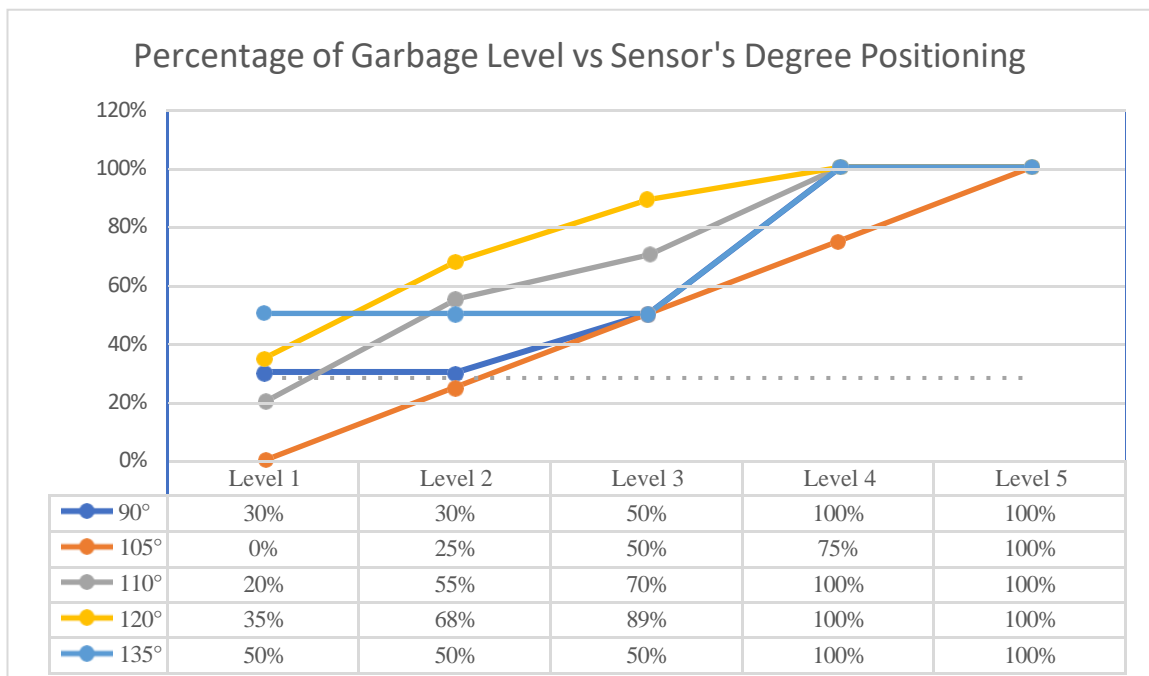

Figure 14. Percentage of Garbage Level vs Sensor’s Degree Positioning

Based on the results in Figure 14, the optimum degree of angle to locate the sensor is 105° from the vertical surface of the garbage bin. The data showed that 105° can give the most accurate and consistent results compared to other degrees of positioning. As per the planned test, the data for 105° when the garbage is at level 1, the garbage level shows 0% of garbage which means the accurate amount of garbage. Other results show the sensor may collect the data incorrectly because the ultrasonic sensor cannot reach the bottom of the garbage bin. Thus, the positioning of the sensor is very important to determine the accuracy of the output data of the sensor, and details testing has been done before the exact position is decided.

3.5. Garbage Level Notification

The Pushbullet application is used to receive notifications from the garbage level monitoring system. Figure 15 shows that the system managed to send push notifications through web and mobile applications.

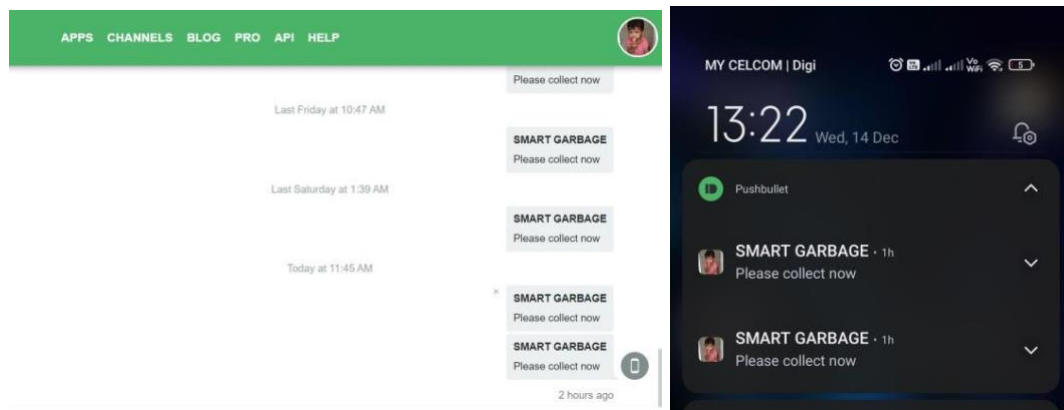

Figure 15. Notification of Alert via Pushbullet Dashboard and Mobile Push Notification

As per tested in Table 2, the system managed to push the notification into the registered mobile device in an average period of 1.3 seconds. The details of the testing results are as per Table 2.

Table 2. Test Result for Notification Duration

Testing No.	Sent Time	Received Time	Time Duration
1	10:32:01	10:32:02	00:00:01
2	10:40:05	10:40:07	00:00:02
3	10:45:29	10:45:29	00:00:01
4	10:56:16	10:56:17	00:00:01
5	11:02:26	11:02:27	00:00:01
6	11:09:15	11:09:17	00:00:02
7	11:17:35	11:17:36	00:00:01
8	11:19:34	11:19:35	00:00:01
9	11:21:51	11:21:52	00:00:01
10	11:23:04	11:23:06	00:00:02

$$\begin{aligned}
 \text{Average time} &= \text{Total Time Duration} / \text{Total Testing Time} \\
 &= 13 \text{ seconds} / 10 \text{ times} \\
 &= 1.3 \text{ seconds}
 \end{aligned}$$

3.6. Overall Performance and Functionality Results

The design of the smart garbage level monitoring and segregation notification systems in terms of hardware and software managed to function well under the conducted experiments. The full functionality tests also demonstrated that the systems were able to run the programmed code with the correct sequence and accuracy.

4. Conclusions

The study has demonstrated that the IoT is very useful in waste management systems in terms of waste segregation and garbage level monitoring system. The proposed waste management system demonstrates a bedrock idea towards managing garbage efficiently in Smart City. The outcome of the designed model, for the waste segregation system, will help to control human behaviour when it is involved in something that hardly is monitored and measured. The garbage level monitoring system helps the authority manage their resource efficiently when collecting garbage. Therefore, it can be benefiting them; in terms of reducing their operation and management costs.

This research has a few limitations that could be addressed in future studies. As the authority to manage the waste, the smart waste management system must include a GPS positioning device to locate the specific garbage can that needs to be collected. The installation GSM network module is also important to locate the device in a remote area and be connected with other IoT layers. Option for waste segregation garbage cans must include plastics, paper, and general waste that have a specific sensor for the detection of the specific material; in order for the waste management can be optimized. A garbage can that has an auto-open and auto-close cover function with multiple sensors for multiple materials can be designed to allow the person to throw the garbage in the correct garbage can. A single garbage inlet with an auto segregation mechanism can help authorities without enforcing strict laws to manage citizens' behaviour. The installation of solar panels can be a power source for smart devices so the device will become a smart green device.

Acknowledgments

This work has been published in cooperation with the Cyber-Physical System (CPS) Research Group of the Razak Faculty of Technology and Informatics, UTM. The authors would like to express special thanks to the resources and lab access given during the development of the systems.

References

- [1] Malaysian Investment Development Authority (MIDA). Waste to Energy for A Sustainable Future. <https://www.mida.gov.my/waster-to-energy-for-a-sustainable-future>. (Accessed: 20 June 2023).
- [2] Chepa, S., Singh, S., Dutt, H., Sharma, A., Naik, S. and Mahajan, H. (2021). A Comprehensive Study of Distinctive Methods of Waste Segregation and Management. 2021 3rd International Sustainability and Resilience Conference: Climate Change. 15-16 November 2021, Sakheer, Bahrain.
- [3] Dessai, H. and Miranda, D. (2021). Garbage Segregation Using Images. 2021 2nd International Conference for Emerging Technology. 21-23 May 2021, Belgaum, India.
- [4] U.S Energy Information Administration (EIA). Waste-to-Energy (Municipal Solid Waste). <https://www.eia.gov/energyexplained/biomass/waste-to-energy.php>. (Accessed: 20 June 2023).
- [5] Jacob, P. M., Kabeer, R., Nair, N., Saji, S. V., Meenakshi and Varghese, R. R. (2019). An Intelligent Solid Waste Management System Using Internet of Things (IoT). International Journal of Recent Technology and Engineering (IJRTE) 8: 2 (Special Issue 4) (2019) 120-125.
- [6] Idwan, S., Mahmood, I., Zubairi, J. A. and Matar, I. (2020). Optimal Management of Solid Waste in Smart Cities Using Internet of Things (IoT). Wireless Personal Communications 110:1 (2020) 485-501.
- [7] Mohanram, P. B., Viswanath, S. K., Musaraf, P. M. M., Karthikeyan R., Chandran, K. R. S. and Deborah S. A. (2021). IoT Based Smart Waste Management Reporting and Monitoring System. 2021 5th International Conference on Computer, Communication, and Signal Processing (ICCCSP 2021). 24-25 May 2021, Chennai, India.
- [8] Yanglu, Yadav, Amit. and Khan, A. (2019). Internet of Things Based Wireless Garbage Monitoring System. 2019 3rd International Conference on I-SMAC (IoT in Social, Mobile, Analytics and Cloud) (I-SMAC 2019). 12-14 Dec 2019, Palladam, India.
- [9] Khan, A. and Khachane, A. (2018). Survey on IOT in Waste Management System. Proceedings of the 2nd International Conference on I-SMAC (IoT in Social, Mobile, Analytics, and Cloud) (I-SMAC 2018). 30-31 August 2018, Palladam, India.
- [10] Ali, N. A., Syafeeza, A. R., Ja'afar, A. S., Abdul Hamid, N. and Ridzuan, M. (2020). Garbage Monitoring Systems Based on Internet-of-Things Application. Journal of Physics: Conference Series 1502:1 (2020) 1-8.
- [11] Jasim, A. M., Qasim, H. H., Jasem, E. H. and Saihood, R. H. (2021). An Internet of Things Based Smart Waste System. International Journal of Electrical and Computer Engineering (IJECE) 11:3 (2021) 2577-2585.
- [12] Kanade, P., Alva, P., Prasad, J. P. and Kanade, S. (2021). Smart Garbage Monitoring System Using Internet of Things (IoT). Proceedings of the 5th International Conference on Computing Methodologies and Communication (ICCMC 2021). 8-10 April 2021, Erode, India.
- [13] Shariff, M. A. S., Durgadevi, P., Raj, R., Malik, R., and Yadav, D. (2022). Optimized Garbage Segregation and Waste Monitoring Process by Using the Internet of Things. 2022 2nd International Conference on Advance Computing and Innovative Technologies in Engineering (ICACITE 2022). 28-29 April 2022, Greater Noida, India.
- [14] Pooja, G., Deepika, R., Shervana, B., and Sumathi, S. (2022). Despercredito - Smart Garbage System. 2022 International Conference on Communication, Computing and Internet of Things (IC3IoT 2022). 10-11 March 2022, Chennai, India.
- [15] Mamatha, K. S., and Jilani, S. A. K. (2020). Smart Real Time Garbage Management System. International Journal of Scientific and Technology Research 9:3 (March 2020) 5245-5248.
- [16] Gayathri, N., Divagarani, A. R., Akhilesh C. D., Aswiin, V. M. and Charan, N. (2020). IOT Based Smart Waster Management System. 2021 7th International Conference on Advanced Computing and Communication Systems (ICACCS). 19-20 March 2021, Coimbatore, India.
- [17] Pardini, K., Rodrigues, J. J. P. C., Diallo, O., Das, A. K., de Albuquerque, V. H. C. and Kozlov, S. A. (2020). A Smart Waste Management Solution Geared Towards Citizens. Sensors 20: 8-2380 (2020) 1-15.